

Fence Elevation A-A

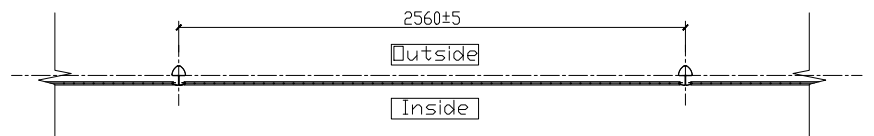

Fence Plan

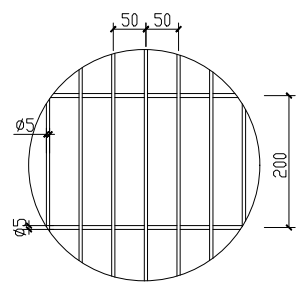

Node B 4:1

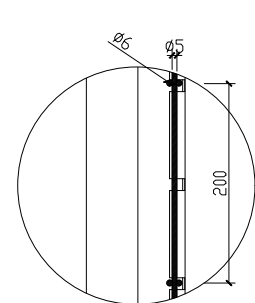

Node C 5:1

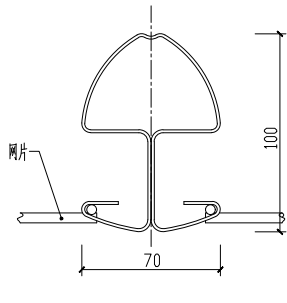

D-D 10:1

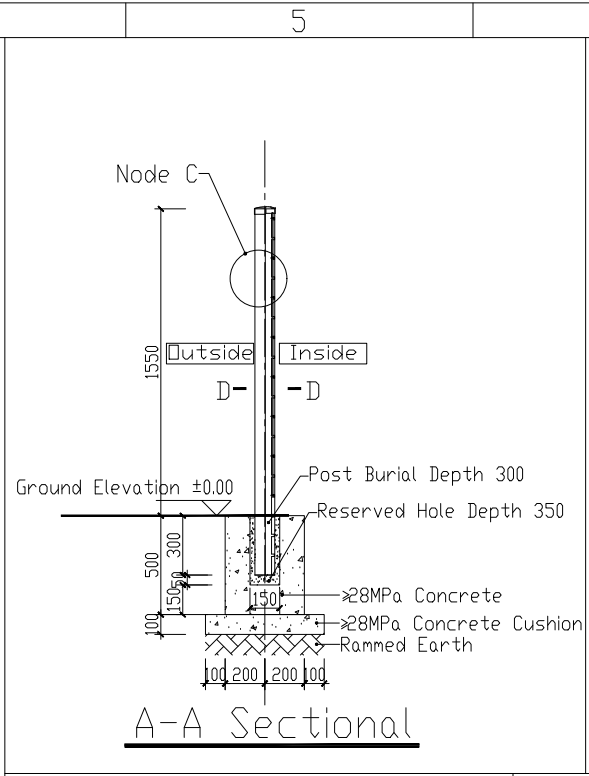

A-A Sectional

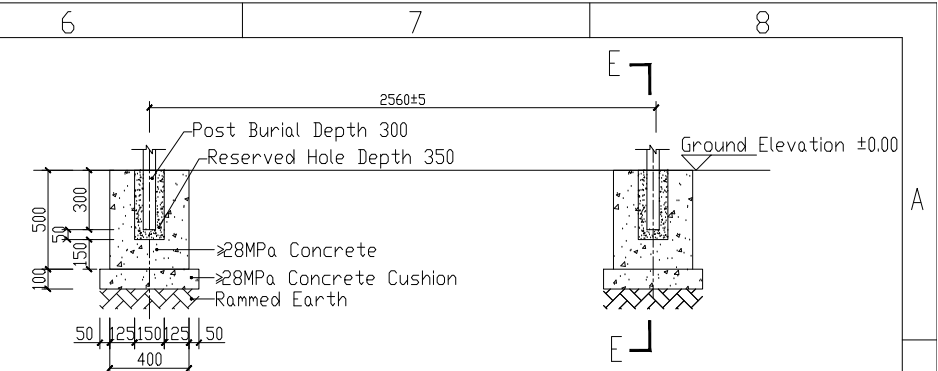

Foundation Elevation

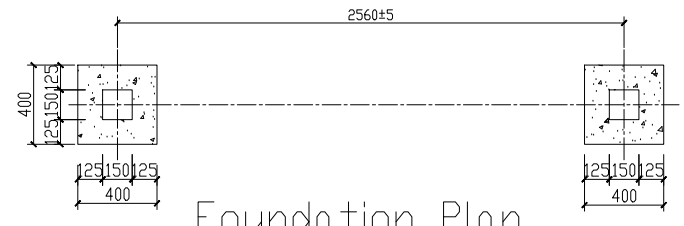

Foundation Plan

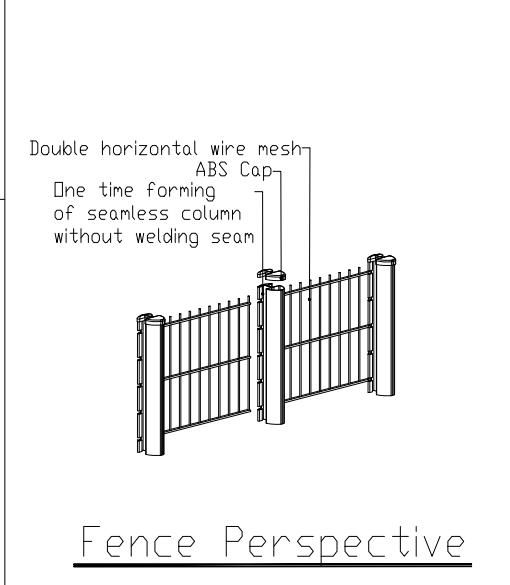

Fence Perspective

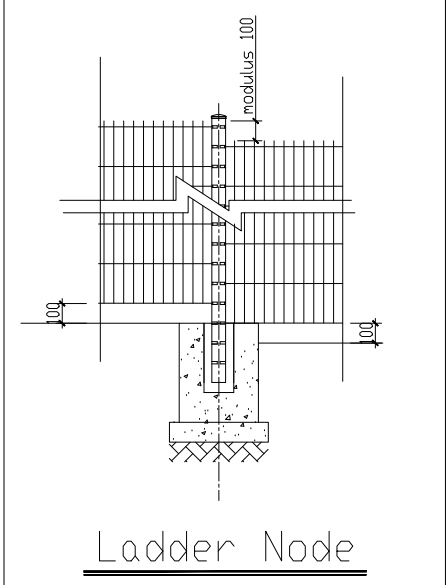

Ladder Node

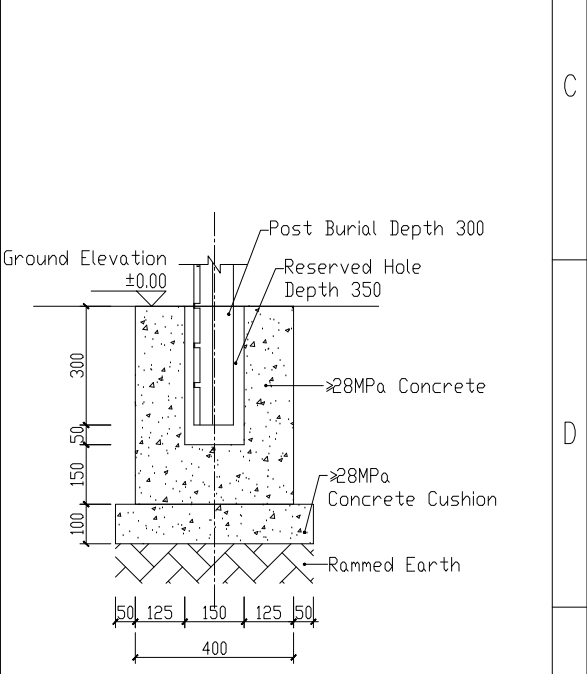

E-E 剖面图 2:1

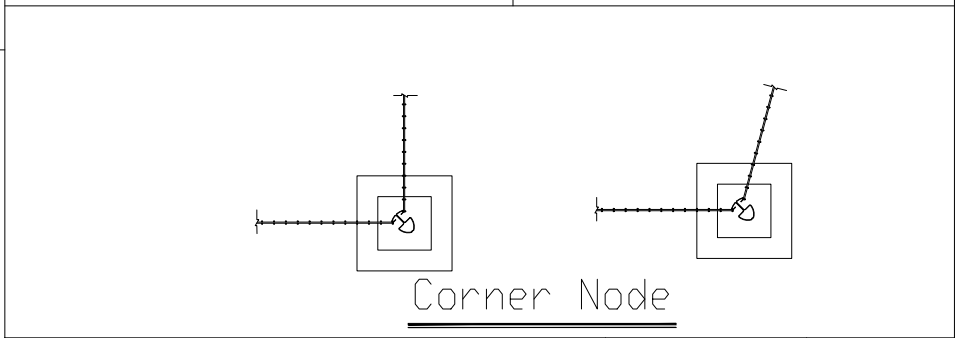

Corner Node

Former outline drawing Number

Outline drawing Number

Signature

Date

Technical Description:  
 1.The dimensions marked in the figure are the centerline dimensions, measured in millimeters;  
 2.The installation height of the fence is 1530 (excluding the foundation), and the center distance of the columns is 2560 ± 5;  
 3.The fence is composed of directly buried columns (including top cover), mesh and other components;  
 4.The column adopts a one-time formed seamless profile, made of continuous hot-dip galvanized steel plate, material DC51D+Z, with a galvanizing amount of ≥120g/m<sup>2</sup> (double-sided);  
 5.The cross-sectional size of the column is 70x100x1.2, with a height of 1850;  
 6.The mesh is made of high-strength cold drawn hot-dip galvanized steel wire resistance welding, material Q195, steel wire tensile strength ≥450MPa, steel diameter Ø6 (horizontal wire)+Ø5 (vertical wire)+Ø6 (horizontal wire), reinforced groove 50 (wire) X100 (horizontal wire), galvanizing amount ≥ 120g/m<sup>2</sup>;  
 7.The height of the mesh is 1430, the width is 2500, and the grid is 50 (threads) x 200 (horizontal threads);  
 8.The surface of the columns and mesh is coated with high adhesion thermosetting polyester powder electrostatic coating, with a coating thickness of ≥100um, coating adhesion of ≥ 0 level, and coating gloss; 80-95°, photo aging ≥ level 0, weather resistance ≥ 5;  
 9.The fence foundation is made of ≥28MPa cast-in-place concrete, with reserved holes for 150x150x350 columns to be buried. After the columns are buried, they are fixed by secondary pouring, with a burial depth of ≥300.

<b>COLLIAND</b>				Project Name:		Project No.	
				Building Name:		Drawing Phase	
Drawn by		Verified by		PSN&TP-1530 Fence construction drawing		Drawing No.	
Designed by		Examined by				Scale	
Checked by		Project Principal				Version	
				Drawing Title:		Date	